



PFS 5

5,700 LITRE PORTABLE FUEL STATION

DESIGNED FOR SMALL USERS, RURAL APPLICATIONS AND ENTRY-LEVEL

NOW WITH

Single hose dispensing as standard incorporating high flow or low flow with the flick of a switch
Up to 2,000 Users and Vehicles, RFID tags included

OPTIONS

Remote access via the internet
Dual hose dispensing incorporating high flow or low flow with the flick of a switch



WHAT MAKES US DIFFERENT?

CAPACITY AND PREMIUM QUALITY

- 📄 5,700 litres safe fill package
- 📄 Large Capacity for up to 2000 users
- 📄 10 year tank structural warranty 2 x 6 mm walls



EASY CUSTOMER RECONCILIATION

**Saves you time and money for each transaction*

- 📄 User Identification and Vehicle Identification
- 📄 Odometer and engine hours
- 📄 Time of filling and fuel quantity

FLOW RATES

- 📄 **PUMP** - Single 1.5 HP submersible turbine ensures the product is always delivered to the dispenser via pressure vs suction so priming lines of an empty tank are not required
- 📄 80 litres per minute suction pump
- 📄 **DISPENSER** - comes with a fitted filter to prevent fuel containment
- 📄 GES dispenser with High or Low flow switch
- 📄 10 meters retractable hi mast, 1" PR hose and auto nozzle



THE TECHNOLOGY



SAFETY FEATURES

- GES innovative 2" mechanical overfill protection allowing fuel company to deliver at 600 lpm flow rates right up to the safe fill level of the tank saving time and money on fuel company deliveries.
- Tank supplied as standard with 15 amp single phase 3 pin electrical cord connection to internal distribution board and isolation RCD's saving on onsite installations costs.
- Controlled operation prevents pump burnout when the fuel level gets too low
- Audible overfill alarms that indicate when the product is too high or too low
- Product-level temperature monitoring
- Emergency stop switches, Enclosed pump bay with lockable doors
- Pump bay fluorescent light, Ladder platform and dip stick

FUEL MANAGEMENT SYSTEM

- Tecalemit FMS 2000 user for the driver, vehicle management and reporting data
- German designed and manufactured Fuel Management Systems for each tank
- European developed technology with USB, 3G, and web cloud base options

ONLINE TANK MONITORING

- GES control ATG remote tank level access gauge via smartphone or web
- Low-level safety pump interlock
- Local Display (1-year free subscription)



PFS 5 - GA DRAWING

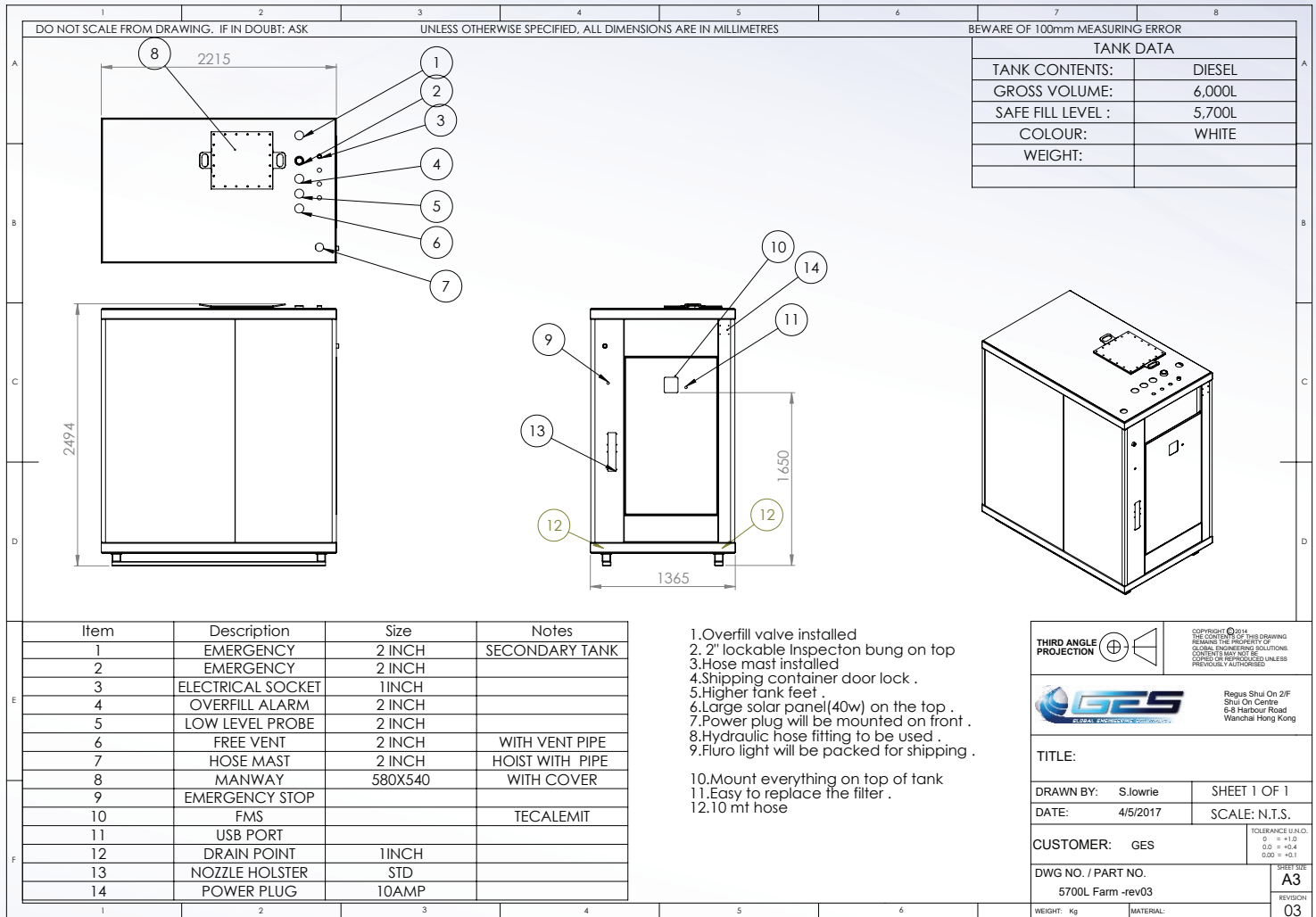

CERTIFICATIONS

- AS 1692-2006** Steel tanks for flammable and combustible liquids
- AS 1940-2004** Storage and handling of flammable and combustible liquids
- CAN/ULC-S601** Shop fabricated steel aboveground tanks for flammable and combustible liquids
- SANS 10131 Ed.1 (2004)** Above-ground storage tanks for petroleum products
- UL 142** Aboveground flammable liquid tanks

FOR MORE INFORMATION, PLEASE CONTACT
Ground Forces Solutions
 Email: info@groundforcesolutions.com.au
 Phone: 1300 969 666